

## LUDE TRANSMISSION

LD Series High-speed linear actuators



**LINEAR MOTION**



## LINEAR MOTION

Lude innovative solutions for high speed and long service life

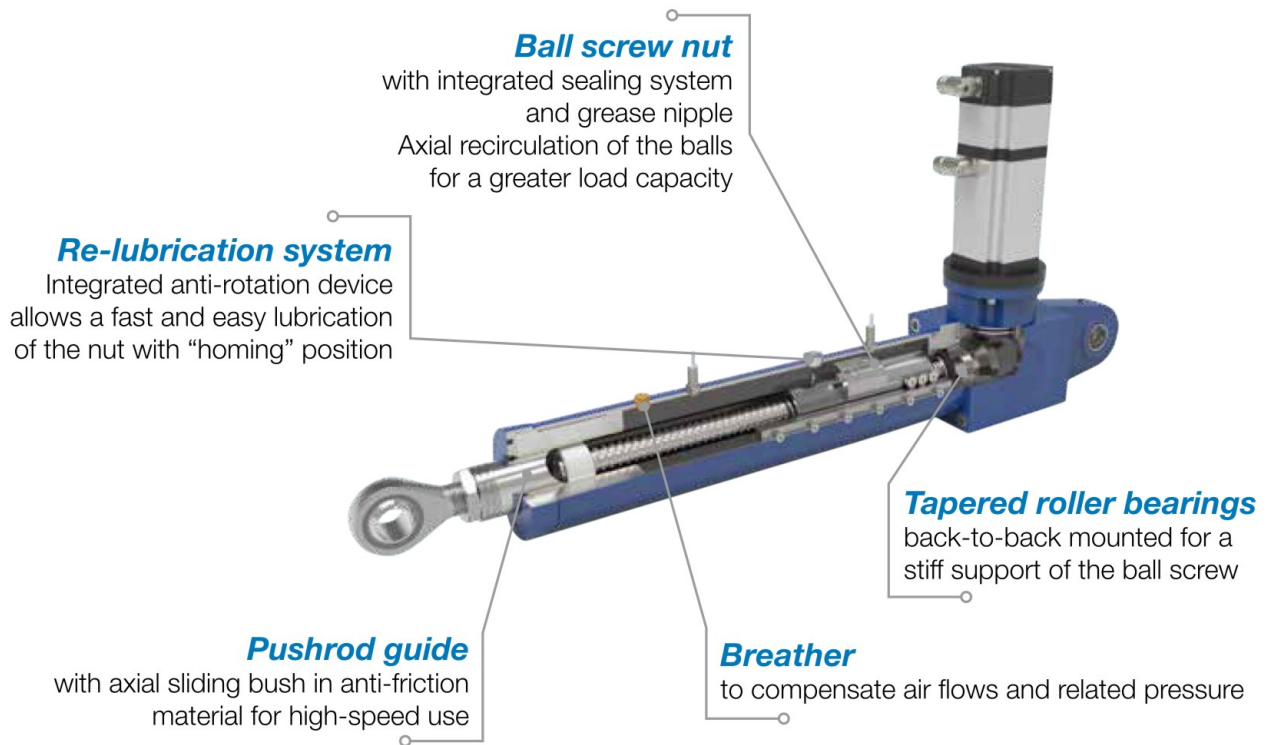

## LD Series

### High-speed linear actuators

Rear hinged attachments

**Gleason** bevel gear

Ball screw drive

**6 sizes**, load capacity from 5 kN to **150 kN**

Ball screw from **Ø 25 mm to Ø 80 mm**

Lubrication with synthetic grease, gearbox long life lubricated,  
fast and easy re-lubrication of the nut with "homing" position.

Linear speed up to **1.500 mm/s**

Standard stroke length up to 1.000 mm

Proximity limit switches

Incremental or absolute encoder for positioning control

Prepared for IEC standard AC motors and brushless servomotors

